

LUBRICATION ORDER

LO 9-2320-218-12

28 JULY 1978 (Supersedes LO 9-2320-218-12) 30 MARCH 1976

TRUCK, UTILITY: ¼ TON, 4X4, M151, M151A1 AND M151A2
TRUCK, UTILITY: ¼ TON, 4X4, M151A1C AND M825
TRUCK AMBULANCE: FRONTLINE, ¼ TON, 4X4, M718 and 718A1

Reference: TM 9-2320-218-10 and TM 9-2320-218-20

Intervals and the related man-hour times are based on normal operation. The man-hour time specified is the time required to perform all the services prescribed for a particular interval. The interval shall be changed to compensate for abnormal operation and severe operating conditions or contaminated lubricants. The interval may be extended during periods of low level activity, commensurate with adequate preservation precautions.

Clean fittings before lubricating. Clean parts with solvent, dry cleaning, SD-2 (P-D-680, Type II). Dry before lubricating. Dotted arrows indicate lubrication on both sides of the equipment.

Relubricate after fording.

—KEY—

LUBRICANTS	EXPECTED TEMPERATURE			LUBRICANTS	INTERVALS See NOTE 6	
	Above +32°F	+40°F to -10°F	0°F to -65°F			
OE HDO—LUBRICATING OIL, INTERNAL COMBUSTION ENGINE (MIL-L-2104)	OE HDO 30	OE HDO 10	OE A	For Arctic Operation — Refer to TM 9-207	OEA—LUBRICATING OIL, INTERNAL COMBUSTION ENGINE (ARCTIC) (MIL-L-46167)	D—Daily (Operator)
GO—LUBRICATING OIL GEAR (MIL-L-2105)	GO85/140 *GO80 90	GO 85/140 *GO80 90	GO75 *GO75		PL-S—LUBRICATING OIL, GENERAL PURPOSE PRESERVATIVE, (WATER DISPLACING, LOW TEMPERATURE) (VV-L-800A)	1—1,000 Miles 6—6,000 Miles or 6 Months*
GAA—GREASE, AUTO MOTIVE AND ARTILLERY (MIL-G-10924)	GAA	GAA	GAA		HBA—FLUID, HYDRAULIC BRAKE, NON-PETROLEUM BASE, AUTOMOTIVE (ARCTIC TYPE) (MIL-H-13910)	12—12,000 Miles or 12 Months* 24—24,000 Miles or 24 Months*
HB—HYDRAULIC FLUID BRAKE, NON-PETROLEUM BASE, AUTOMOTIVE (VV-B-68)	HB	HB	HBA			*Whichever comes first

*STEERING GEAR ONLY

TOTAL MAN-HR		TOTAL MAN-HR	
INTERVAL	MAN-HR	INTERVAL	MAN-HR
D	.1	12	4.5
1	1.5	24	6.0
6	2.5		

LUBRICANT INTERVAL

INTERVAL LUBRICANT

Front Differential
Fill and Level
(Check level)

GO 1

1

GAA Steering Linkage
(See note 1)

Air Cleaner
(See note 1)

OE/
HDO 1

12

GO Front Differential
Drain
(Drain and refill
Cap. 2 pts.
See note 5)

Steering Gear
Fill and Level
(Check level)

GO 1

OE/
HDO Crankcase Fill
(See note 2)

Brake Master
Cylinder
(Fill to bottom
threads of filler
hole)

HB 1

D

Crankcase Level
(Check level)
(See note 2)

Transfer Drain
(Drain at time of
transmission drain)

GO 24

12

OE/
HDO Crankcase Drain
(Drain and refill)
(Cap. 5 qts.)
(See note 2)

Rear Differential
Fill and Level
(Check level)

GO 1

6

Engine Oil Filter
(See note 3)

Pintle
(2 fittings)

GAA 1

1

Distributor
(See note 4)

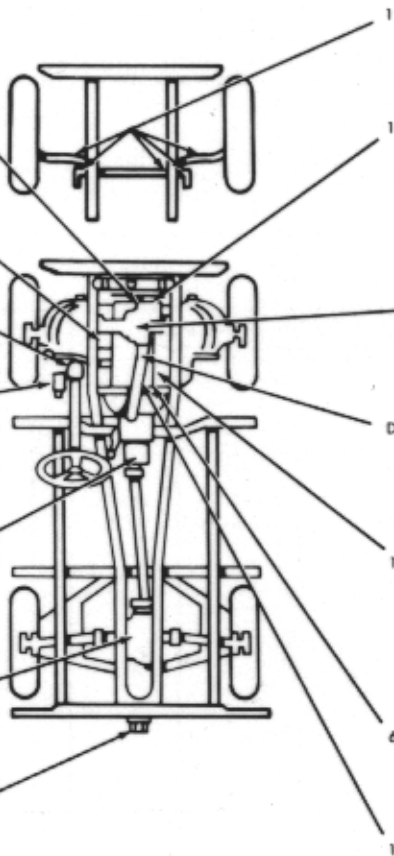

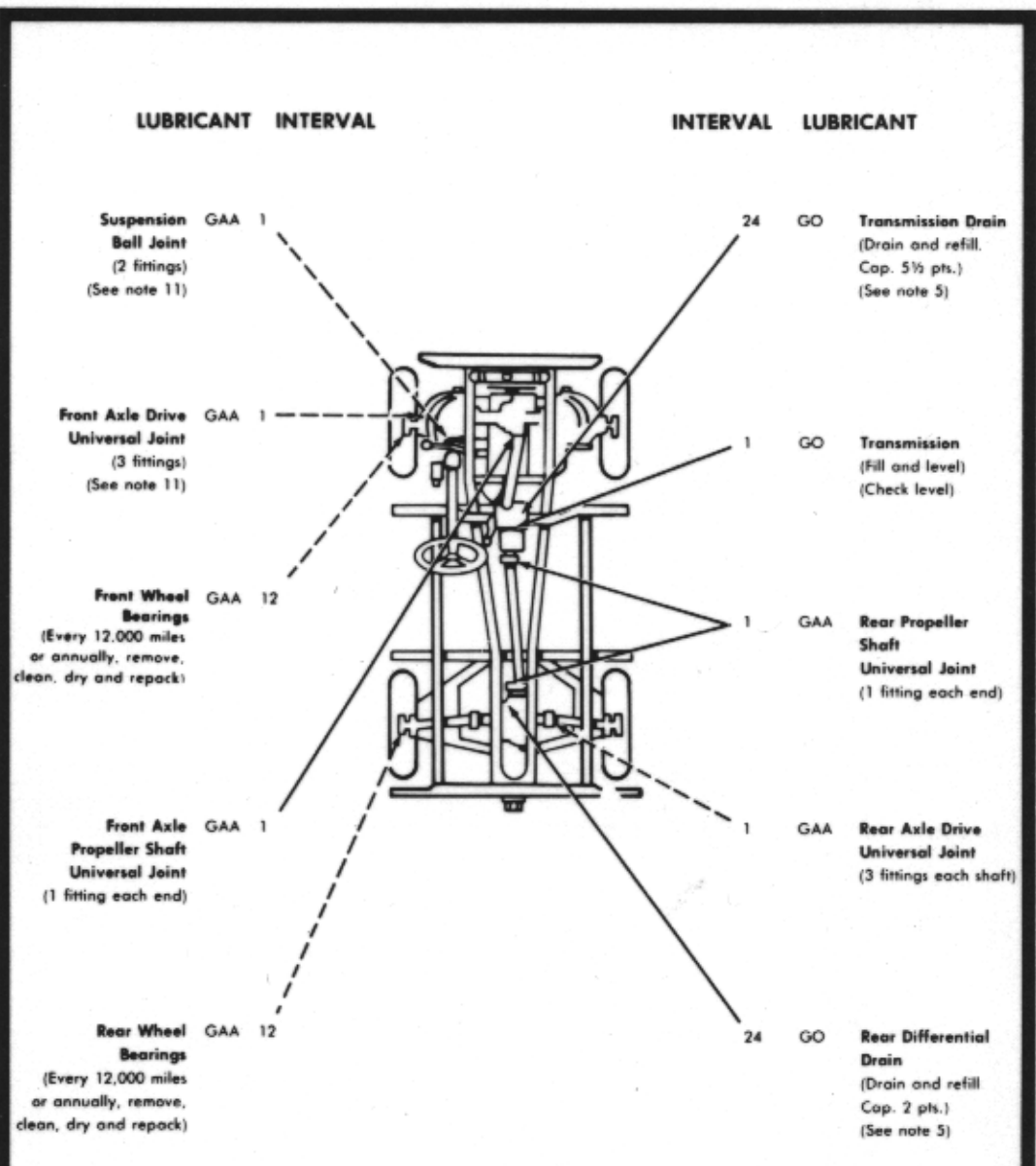

—NOTES—

1. AIR CLEANER

Every 1,000 miles, clean oil reservoir and refill with approximately 2½ pints of OE/HDO crankcase grade. Disassemble and clean all parts. Refill with OE/HDO, as above, whenever crankcase oil is changed. For desert, or extremely dusty conditions, disassemble, clean all parts and refill with OE/HDO once every operating day, or more frequently if required. Inspect air cleaner intake tube for splitting, tightness of

connection to air cleaner, and security of attachment to body.

2. CRANKCASE

Drain every 12,000 miles or annually. Drain oil only when engine is hot. Clean magnetic drain plug before replacing. Refill to full mark with OE/HDO. Do not exceed FULL mark on dipstick. Under adverse conditions it may be necessary to drain the crankcase oil more frequently. Check level daily. Safe operating level is between ADD and FULL on dipstick.

3. OIL FILTER

Every 6,000 miles or semiannually, remove oil filter assembly and discard. Install new oil filter assembly.

4. DISTRIBUTOR (STANDARD AND SOLID STATE)

Every 6,000 miles or semiannually, remove cover assembly and rotor. Saturate felt at rotor end of shaft with 2 to 3 drops of PL-S. Remove slotted plug under nameplate on distributor housing and withdraw wick. Soak wick in PL-S. Fill plug opening with GAA. Insert wick, remove excess grease and install plug. Wipe breaker cam sparingly (standard only) with GAA and lubricate breaker arm pivot with 1 or 2 drops of PL-S.

5. GEARCASES

NOTE

If oil is checked when hot, expansion from heat may cause oil to run out of check hole. This is normal and oil should not be drained. Do not check during road halts unless a class III leak is identified.

Drain every 24,000 miles or 24 months. Drain only when hot after operation. Fill to plug level before operation and after draining. Clean vents, especially after an operation in water or mud. Clean magnetic drain plug before replacing.

6. LUBRICATION INTERVALS

This LO has been revised to comply with the DA Program to extend intervals to conserve lubricants. When practical, Lubrication Service will be made to coincide with the vehicle "S" P.M. Service. For this purpose a 10% tolerance (Variation) in specified Lubrication Point mileage is permissible. Those vehicles not accumulating 1,000 miles in a 6 month period will be lubricated at the time of P.M. Service.

7. OIL CAN POINTS

Every 1,000 miles, lubricate all doors and compartment hinges, latches, hood catches, throttle bellcrank, carburetor linkage, seat adjusting screw, spare tire wing nut, accelerator pedal pivot pin, seat retaining pins and rear seat pivot pins and vehicle lifting eyes with PL-S.

8. DO NOT LUBRICATE

Shock absorber bushings, or front and rear suspension support arm pivots.

9. LUBRICATE AT TIME OF ASSEMBLY BY DIRECT SUPPORT PERSONNEL

Ventilator valve assembly, generator assembly, starter assembly and speedometer cable assembly.

10. BRAKE FLUID

Use hydraulic brake fluid (HB) non-petroleum base only. Use of hydraulic brake fluid petroleum base renders brakes inoperative.

11. SPECIAL INSTRUCTIONS

Lubricate only those ball joints and steering linkage joints having lubrication fittings. Lube-for-Life components do not require lubrication. Special stress should be made to lubricate each lube point until clean lubricant comes through the seals. Before operation, check level of radiator coolant. (Refer to TB 750-651).

12. REPORTING OF ERRORS

You can improve this Lubrication Order by recommending improvements, using DA FORM 2028 (Recommended Changes to Publications). Mail your comments direct to:

COMMANDER
U.S. ARMY TANK-AUTOMOTIVE
MATERIEL READINESS COMMAND
WARREN, MICHIGAN 48090
Attn: DRSTA-MBA

A reply will be sent directly to you.

Copy of this Lubrication Order will remain with the vehicle at all times. Instructions contained herein are mandatory and supersede all conflicting lubrication instructions dated prior to the date of this Lubrication Order.

BY ORDER OF THE SECRETARY OF THE ARMY:

BERNARD W. ROGERS
General, United States Army
Chief of Staff

OFFICIAL:

J.C. PENNINGTON
Brigadier General, United States Army
The Adjutant General

LO 9-2320-218-12 DISTRIBUTION: To be distributed in accordance with DA Form 12-38, LO requirements for Truck, 1/2 Ton, 4x4, M151.